

Simulation-Based Analysis of Unified Power Quality Conditioners for Power System Stabilization

Rohan V. Mehta and Dr. Aparna S. Kulkarni

Department of Electrical Engineering, National Institute of Technology, Hamirpur, Himachal Pradesh, India

ABSTRACT

Nowadays, widespread use of power electronics based load in house-hold and industry have increased the importance and application of power Quality studies. Power electronic devices having property of non-linearity draw harmonic and reactive power from the source. Unified Power Quality conditioner (UPQC) is the device that mitigates the harmonics and improves the quality of power. This paper presents the working principle of UPQC based on instantaneous p-q theory which compensates the load current harmonics and reactive power at the load side. The performance of the proposed UPQC and its controller is tested through MATLAB SIMULATION.

Keywords: UPQC, shunt active filter, hysteresis current controller.

I. INTRODUCTION

Power Quality issues are becoming more and more significant because of the increasing number of power electronic devices used in house-hold and industry. These devices draw harmonics and reactive power from the source and distort the quality of power. Power electronics based load are very sensitive to quality of power supply. If the quality of power supply is poor, then such devices may misbehave and sometime it may destroy. So power quality issue becomes more concern these days.

Unified Power Quality Conditioner (UPQC) is novel devices that compensate the reactive power drawn by the load and it also mitigates the harmonics produced by the load. It is a custom power device which consists of shunt active power filter that compensate harmonics and reactive power. UPQC system can be divided into two units, first is control unit and the second one is power circuit. The task of control unit are disturbance detection, reference signal generation, gate signal generation and, currents measurement. Power circuit consists of current source inverter.

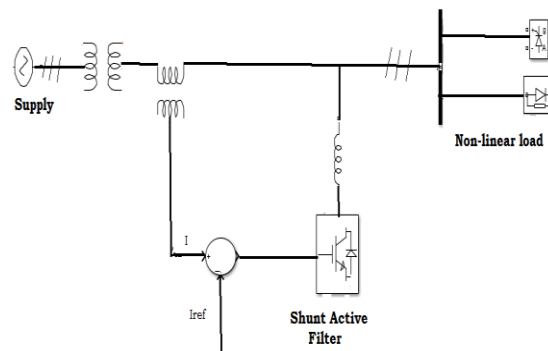

Figure. 1. Line diagram of Unified Power Quality Conditioner

II. UPQC TOPOLOGY

The concept of instantaneous active and reactive power and its application for reference current generation in shunt active filter was introduced by Akagi et al. [1]. Three-phase voltages are transformed from a-b-c to - frame and vice versa using the Clarke transformation as follows:

$$= \dots\dots(1)$$

$$= \dots\dots(2)$$

The same transformation matrix applied for the transformation of currents as:

$$= \dots\dots(3)$$

$$= \dots\dots(4)$$

The instantaneous active and reactive power for three-phase three-wire system is defined as:

$$= \dots\dots\dots(5)$$

Then from equation (5) currents and are expressed as:

$$=1/(+) \dots\dots(6)$$

Both active and reactive power defined in equation (5) are composed of two components, one is constant (or DC) part and another is oscillating part. Thus we can write it as:

Real power: $p = +$

Imaginary power: $q = +$

where and are the average (or DC) parts of active and reactive power originating from the positive sequence (symmetrical fundamental component) of the load currents. is the average active power delivered to the load whereas is average reactive power drawn by the load. For improving the power factor has to be totally or partially compensated by the shunt active power filter.

and are the oscillating components of the active power and reactive power (ac value). Oscillating components (and) originates because of the harmonics and asymmetrical (negative sequence) components of load currents. If applied voltages and currents are symmetrical and undistorted then these oscillating components will become zero and if any one of them is asymmetrical then and will be non-zero. But in many cases, supply voltages asymmetrical and distortion are so small that they can be neglected. When the load currents are symmetrical and undistorted , = 0 and =0 and if there is any distortion in load currents , and will be different from the zero and it will be compensated by the shunt active filter.

III. SWITCHING TOPOLOGY FOR SHUNT ACTIVE FILTER

Shunt active power filter connected in parallel with load to suppress the harmonics produced by the non-linear elements. It generate the compensating currents, and, to compensate the load currents, and, to make the current drawn from the source sinusoidal and balanced. Hysteresis current control method is used for switching purpose of the inverter. In this technique, reference currents are compared with the currents produced by the shunt active filter. Reference currents are obtained with the help of instantaneous p-q theory as:

$$= 1/(+) \dots\dots\dots(7)$$

$$= \dots\dots\dots(8)$$

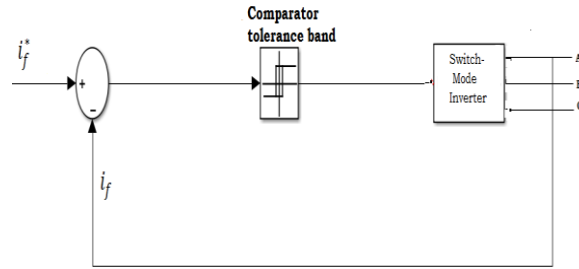

Figure. 2. Hysteresis current control scheme for generation of gating pulse

Reference currents obtained from equation (8) are compared with shunt active filter currents, and, . A band is formed with the ripple of the shunt active filter current and if the filter current tries to go beyond the hysteresis band, switching action will take place. Switching action will take place in such a way that, if current tries to go beyond the hysteresis band, it turns OFF the positive side switch and if current tries to cross the low side barrier, upper switch will turn ON. In this technique, switching frequency directly depends upon the shunt active filter current profile. The frequency of switching also varies if there is any change in load current profile. This technique is also known as delta modulation, adaptive current and tolerance band current control.

IV. SIMULATION OF UPQC

Simulation diagram of proposed UPQC is shown in Figure (3). Non-linear load connected through the three-phase supply produced harmonics in load current. Control unit detects the current distortion and generates appropriate gate signals for proper operation of shunt active filter. Gate signals are generated in such a manner in which shunt active filter injects appropriate currents in the line so that source current will remain in a sinusoidal state.

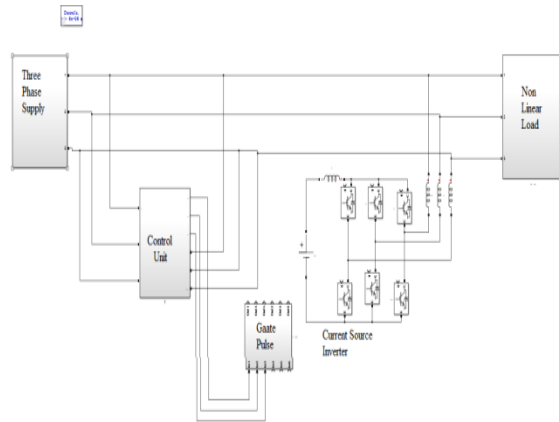

Figure. 3. SIMULATION diagram of proposed UPQC

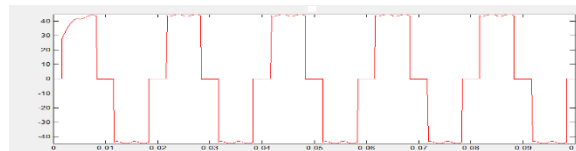

Figure. 4. Distorted line current

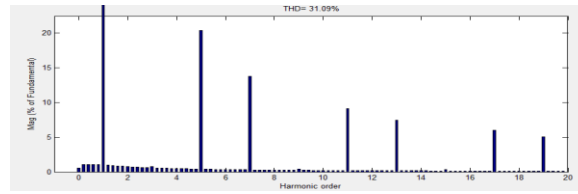

Figure 5. THD analysis of distorted current waveform

Simulation results of distorted line current are shown in Figure (4) and its fft analysis I given in Figure (5). Total Harmonic Distortion (THD) of the system before compensation is 31.09%.

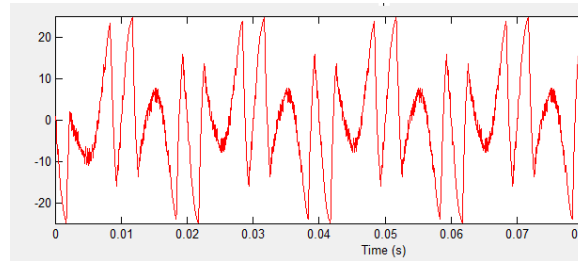

Figure 6. Compensating current injected by hunt active filter

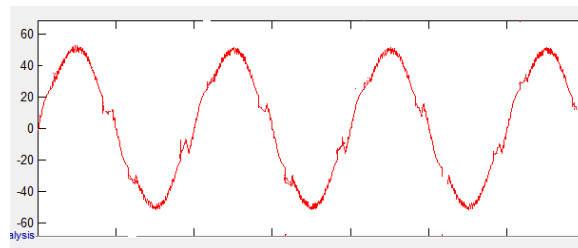

Figure 7. Resultant line current after current compensation

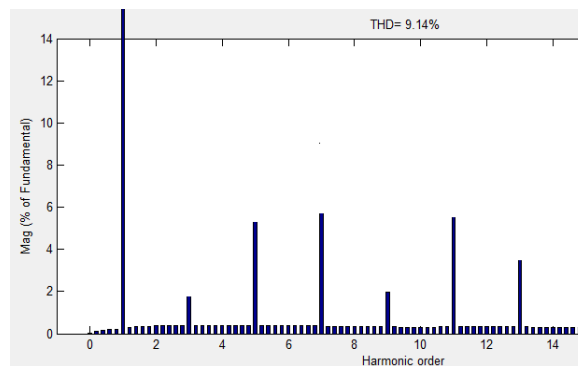

Figure 8. THD analysis of resultant line current

Current injected by shunt active filter is shown in Figure (6). After the current compensation by the hunt active filter, the resultant line current in shown in Figure (7). Resultant line current is approximately sinusoidal and its THD content reduced from 31.09% to 9.14%.

V. CONCLUSION

With the installation of non-linear load, power quality problem arises. In this paper, control mechanism for shunt active filter has been presented. The control mechanism is based on hysteresis current control method in which output current of filter always reside under the hysteresis band. With the help of MATLAB SIMULATION FFT analysis, we analyze the UPQC. Simulation result under the condition of non-linear load connected with three-phase supply has verified. The result shows that it is an effective tool for harmonic mitigation.

REFERENCES

- [1] H. Akagi, "New trends in active filters for power conditioning," *IEEE Trans. Ind. Appl.*, vol. 32, no. 6, pp. 1312–1322, Nov.-Dec. 1996.
- [2] B. Singh, K. Al-Haddad, and A. Chandra, "A review of active power filters for power quality improvement," *IEEE Trans Ind. Electron.*, vol.45, no. 5, pp. 960–971, Oct. 1999.
- [3] L. Monterio, M. Aredes, and J. Neto, "A control strategy for unified power quality conditioner," in *Proc. Annu. Conf. IEEE Industrial Electronics Symp.*, 2003, vol. 1, pp. 391–396.
- [4] H. Akagi, H. Fujita, "A New Power Line Conditioner for Harmonic Compensation in Power Systems," ***IEEE Transactions on Power Delivery***, Vol. 10 (3), July 1995.
- [5] S. Fryze, "Active, reactive and apparent powers in circuits with distorted voltages and currents," *ETZ*, vol. 53, pp. 596–599, 1932.
- [6] J. L. Willems, "Critical analysis of the concepts of instantaneous power current and of active current," in *Proc. Europe. Trans. Elect. Power*, vol. 8, July/Aug. 1998.
- [7] F. Z. Peng and J.-S. Lai, "Generalized instantaneous reactive power theory for three-phase power systems," *IEEE Trans. Instrum. Meas.*, vol. 45, no. 1, pp. 293–297, Feb. 1996.
- [8] H. Akagi, S. Ogasawara, and H. Kim, "The theory of instantaneous power in three-phase four-wire systems: A comprehensive approach," in *Proc. Conf. Rec. IEEE Ind. Applicat. Conf.*, vol. 1, 1999, pp. 431–439.
- [9] N. Mohan et al., "Active filters for ac harmonic suppression," presented at the IEEE/PES Meeting, 1977, A77 026-8.