

Frequency Domain Analysis of High Frequency Inverters for Advanced Induction Heating Applications

Kunal R. Kulkarni and Dr. Ramesh C. Gavaskar

Kunal R. Kulkarni, P.G. Student, Department of Electrical Engineering, Visvesvaraya National Institute of Technology, Nagpur, Maharashtra, India; and Dr. Ramesh C. Gavaskar, Professor, Department of Electrical Engineering, Coimbatore Institute of Technology, Coimbatore, Tamil Nadu, India.

ABSTRACT

This paper presents modelling and simulation of high frequency inverter for induction heating applications. Induction heating has advantages like higher efficiency, controlled heating, safety and pollution free therefore this technology is used in industrial, domestic and medical applications. The high frequency full bridge inverter is used for induction heating, also MOSFET is used as a switching device for inverter and the control strategy used for inverter is Bipolar PWM control. The size of converter and component size are reduced by using higher switching frequency. The series resonant tank is designed and is connected to the output side of transformer to produce higher amount of current in work piece to be heated.

Keywords: Full bridge inverter, High frequency, Induction heating, Pulse Width Modulation (PWM).

I. INTRODUCTION

Now a day's global warming effects and environmental issues are the main problems which lead to increase the carbon-dioxide in atmosphere. Conventional heating method from coal, wood and gas releases carbon-dioxide gas which is related with global warming and greenhouse effects. So products having better quality, safe, efficient, less energy consumption demand is rising. Induction heating is preferred over conventional heating method due to its advantages like quick start, easy temperature control, and free from pollution. By using power electronics devices and advanced control techniques one can develop reliable and cost effective systems. The working principle of induction heating is similar to the transformer. The work coil is like primary of transformer which has many turns excited by an ac source and work piece is like a short circuit single turn secondary of transformer. So the amount current flowing through the work piece is very large.

Induction heating is a non-contact heating method between induction coil and work piece. The work piece that can be heated is placed in single or multi turn coil. When ac supply is given to coil, it causes eddy current induced into a work piece which produces heating effect. Also a high frequency used in induction heating applications gives rise to phenomenon called skin effect that increases the resistance of the work piece to the passage of large amount of current. The skin depth is depth of penetration of which current is flowing.

Skin depth is given by formula

$$\delta = \sqrt{\frac{\rho}{\pi \mu f}}$$

Where f is operating frequency

ρ is electrical resistivity of the material.

μ is magnetic permeability of the material.

The skin depth is inversely proportional to frequency, by increasing frequency the depth of penetration decreases and vice versa.

II. INVERTER

Inverter changes dc input to a symmetric ac output voltage of desired magnitude and frequency. The output

frequency of an inverter is calculated by switching on and off the semiconductor devices by control circuit. The output voltage of an inverter is fixed or variable at fixed or variable frequency. By varying the input dc voltage and maintaining gain of inverter constant we can get variable output voltage.

Selection of Inverter is depend upon following factors

1. Current rating
2. Voltage rating
3. Power handling capacity

For low power application the half bridge inverter can be selected and for high power application the full bridge inverter can be selected.

A.PWM Techniques

Generally following are the PWM techniques used in inverter

- A1. Single pulse width modulation
- A2. Multiple pulse width modulation
- A3. Sinusoidal pulse width modulation
- A4. Modified sinusoidal pulse width modulation
- A5. Phase displacement control

A2. Multiple pulse width modulation

The main advantage of this method is to reduce the harmonic content by using several pulses in each half cycle of the output voltage. The output is obtained by comparing the carrier wave and reference wave and it depends on modulation index.

The frequency modulation ratio is given by

$$m_f = \frac{f_c}{f_o}$$

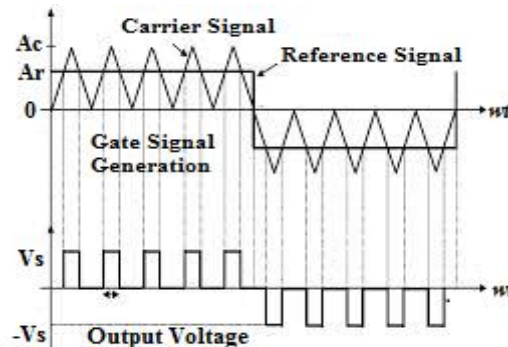

Fig. (a) Multiple pulse width modulation

A3. Sinusoidal pulse width modulation

The widths of pulses in multiple pulse width modulation are same but in sinusoidal pulse width modulation width of each pulse is varied proportional to the amplitude of the sine wave. By comparing sine wave with triangular wave the output is obtained and frequency of reference signal calculated the inverter output frequency and its peak amplitude control the modulation index and then rms output voltage.

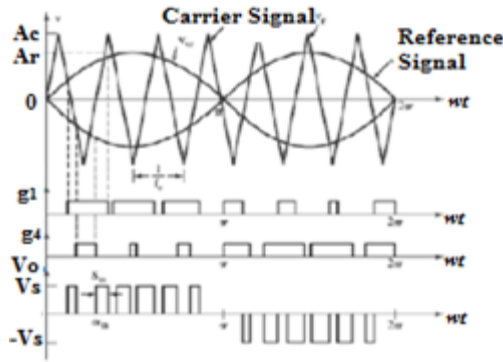

Fig. (b) Sinusoidal pulse width modulation

III. TYPES OF INVERTER

A. Square Wave Inverter

Square wave inverter is as shown in fig.(c) it consist of four semiconductor switches namely S1,S2,S3,S4 .

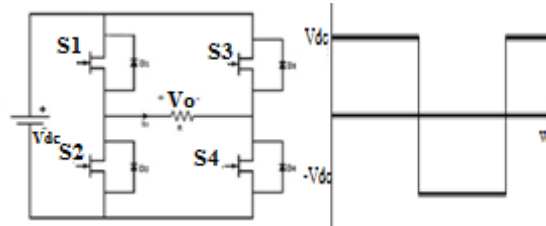

Fig.(c) Square wave inverter

When voltage is applied to the inverter then switch S1 and S4 are turned on, the output voltage across load is Vdc. When switch S3 and S2 are turned on, the output voltage across load is -Vdc. The output voltage waveform of the inverter is as shown in fig.(c)

B. Pulse width Modulated (PWM) Inverter

If the input dc voltage is constant then inverter control the magnitude and frequency of the output voltage and this is done by PWM of the inverter switches so this inverter is called as PWM inverter.

Following are the methods of voltage switching.

- 1. PWM with Unipolar Voltage Switching
- 2. PWM with Bipolar Voltage Switching

1. PWM with Unipolar Voltage Switching

In unipolar PWM method two sinusoidal modulating waves Vsine and -Vsine are 180° out of phase and triangular wave is compared with both the sine waves to get output.

When Vsine > Vtrian then switch S1 is on.

When Vsine < Vtrian then switch S4 is on.

When -Vsine > Vtrian then switch S3 is on.

When -Vsine < Vtrian then switch S2 is on

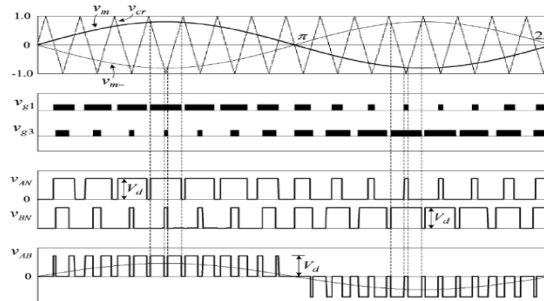

Fig.(d) waveform of PWM with Unipolar Voltage Switching

2. PWM with Bipolar Voltage Switching

In bipolar PWM method, sine wave is considered as the reference wave and triangular wave as a carrier wave is as shown in fig.(e). After comparing both the waveform the output voltage is obtained. When V_{sine} is greater than the $V_{triangular}$ then output voltage is $+V_{dc}$ and when V_{sine} is less than the $V_{triangular}$ then output voltage is $-V_{dc}$. In this project the Bipolar PWM technique is used.

Advantages of Bipolar voltage switching are

1. Increasing switching frequency possible to change the magnitude and frequency of output voltage.
2. By increasing frequency Ripple is decreased.
3. Low switching losses in the inverter switches.

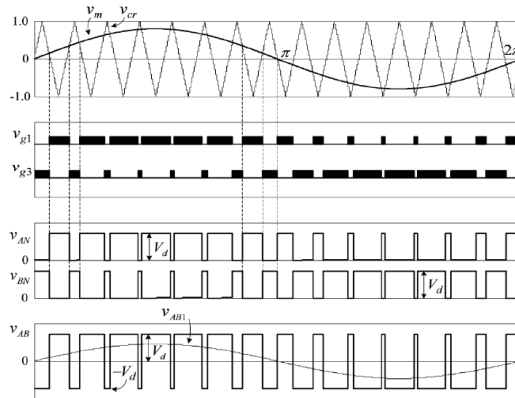

Fig.(e) Waveform of PWM with Bipolar Voltage Switching.

IV. INVERTER TOPOLOGIES

Following are inverter topology that are mostly used

1. Push Pull Topology
2. H Bridge Topology
3. Flyback topology

1. Push Pull Topology

The square wave is obtained in push pull topology. The push pull topology is basically a forward converter with two primary winding and the core of transformer more efficient than the flyback or the forward converter. Push pull converter requires smaller filter and it used for high power application.

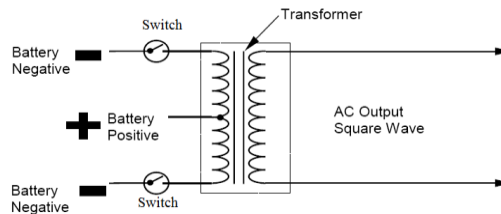

Fig.(f) Push Pull Topology

When top switch is closed then current flows from negative terminal of battery through the primary winding of transformer to the positive terminal of battery. At one time only one switch is closed and output voltage is obtained in secondary side. After some period the top switch is open and bottom switch is closed that passing the current in opposite direction.

2. H Bridge Topology

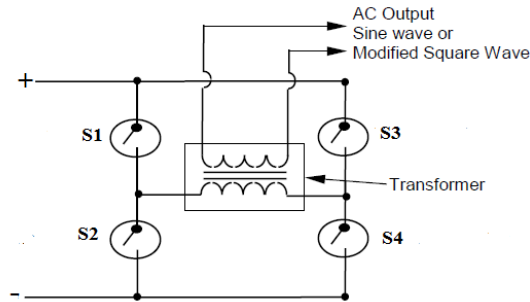

Fig.(g) H-Bridge Topology

When voltage is applied then switch S1 and S4 are turn on and current flows from positive terminal to switch S1 through primary of transformer to switch S4 to negative terminal of battery. After some period Switch S3 and S2 are turn on then current flows from positive terminal to switch S3 through transformer primary to switch S2 to negative terminal. In this project the H-Bridge topology is used.

Following are the advantages of H bridge topology

1. Higher Power handling capacity.
2. Less losses in the switches during turn on.
3. Less size and weight of high frequency switches.

V. Design of Single Phase Full Bridge Inverter and High Frequency Transformer

A. Design of Single Phase Full Bridge Inverter

The following are the specified values of an inverter,

Nominal input voltage = 250 volt

Maximum input voltage=240 volt

Nominal output voltage V_{out} = 2 volt

Switching frequency f =50 KHz

Following are the steps to calculate parameter of the Full bridge inverter

Step1.Switching period

$$T = \frac{1}{f} = \frac{1}{50 \cdot 10^3} = 20 \mu\text{sec}$$

Step2.Maximum duty cycle

Maximum duty cycle is

$$\begin{aligned} t'_{on} &= 0.5 * T \\ &= 0.5 * 20 * 10^{-6} \\ &= 10 * 10^{-6} \text{sec.} \end{aligned}$$

To avoid the simultaneous switch condition the maximum duty cycle is

$$D_{max} = 0.9 * \frac{t'_{on}}{T} = 0.45$$

$$T_{on\ max} = 0.45 * 20 \mu\text{sec} = 9 \mu\text{sec.}$$

Step3. The input power is

$$\begin{aligned} P_{input} &= V_{in} * I_{in} * p.f. \\ &= 250 * 5 * 0.9 \\ &= 1125 \text{ watt} \end{aligned}$$

Step4. Maximum average input current

$$\begin{aligned} I_{in} &= \frac{P_{in}}{V_{in\ min}} \\ &= \frac{1125}{240} = 4.68 \text{ Amp.} \end{aligned}$$

B. High Frequency Transformer Design

Following are the steps to calculate parameters of High frequency transformer

Step1. Calculation of primary turns

$$N_1 = \frac{V_{inmax} * Dmax * T}{\Delta B * A_c}$$

$$= \frac{240 * 0.45 * 20 * 10^{-6}}{0.05 * 3.68 * 10^{-4}}$$

$$N_1 = 117.39 = 117 \text{ Turns}$$

Step2. Calculation of Secondary turns

$$N_2 = N_1 * N$$

$$= 117.39 * 9.25 * 10^{-3}$$

$$N_2 \approx 2 \text{ Turns}$$

Step3. Maximum average output current

$$I_{out} = \frac{P_{out}}{V_{out}} = \frac{200}{2} = 100 \text{ A.}$$

Step4. Electrical condition parameter calculation K_g :

$$K_g = 0.145 * K_f^2 * f^2 * B_m^2 * 10^{-4}$$

Where K_f is the waveform coefficient and for square wave its value is 4.

$$K_g = 0.145 * 4^2 * (50 * 10^3)^2 * 0.05^2 * 10^{-4}$$

$$= 1450$$

Step5. Calculation of the core Geometry parameter K_g

$$K_g = \frac{P_t}{2 * K_g * \alpha}$$

$$= \frac{1125}{2 * 1450 * 1}$$

$$= 0.3879$$

Select ETD 59/31/22 Ferrite Core Transformer

$$K_g = \frac{W_a * A_c^2 * K_u}{MLT}$$

Where,

K_g is the core geometrical parameter constant,

W_a is core window area,

A_c is cross sectional area and

MLT is mean length per turn.

For ETD 59/31/22 following are the parameter

$$W_a = 5.17 \text{ cm}^2$$

$$A_c = 3.68 \text{ cm}^2$$

$$l_g = 13.9 \text{ cm}$$

$$K_g = \frac{5.17 * (3.68)^2 * 0.2}{13.9}$$

$$= 1.007$$

Effective core parameter

Sr .n o.	SYMBOL	PARAMETER	VALUE	UNIT
1	$\epsilon (I/A)$	Core factor (CI)	0.378	mm^{-1}
2	V_e	Effective volume	51500	mm^3
3	l_e	Effective length	139	mm
4	A_e	Effective area	368	mm^2
5	A_{min}	Minimum area	360	mm^2
6	m	Mass of core half	=130	g

Table1.Effective core parameter of ETD 59/31/22.

Fig.(h) shows the core structure of ETD59/31/22 where all the dimensions are in mm.

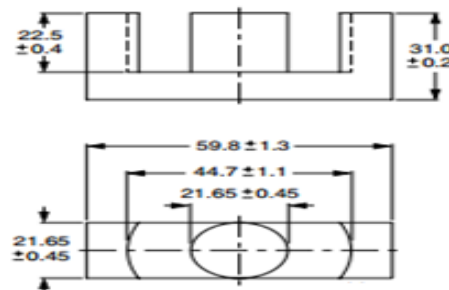

Fig.(h) ETD Core 59/31/22

Step6. Calculation of Skin depth

The skin depth δ is give by the formula

$$\delta = \frac{6.62}{\sqrt{f}}$$

$$= \frac{6.62}{\sqrt{50 * 10^3}}$$

$$\delta = 0.0296$$

Step7.Calculation of primary and secondary conductor size/gauge of transformer

For copper conductor current density taken as $J=5A/mm^2$

Area of primary conductor of transformer

$$a_1 = \frac{\text{primary current}}{\text{current density}}$$

$$= \frac{4.68}{5}$$

$$= 0.936mm^2$$

Area of secondary conductor of transformer

$$a_2 = \frac{\text{secondary current}}{\text{current density}}$$

$$= \frac{100}{5}$$

$$= 20 mm^2$$

VI. RESONANT CIRCUIT

1. Series resonance circuit
2. Parallel resonance circuit

1. Series resonance circuit

In RLC series circuit the resonance is occur when the capacitive and inductive reactance are equal in magnitude. When resonance occur the amount of energy stored in inductor is transferred to capacitor and capacitor transferred the energy to inductor, so total energy stored in circuit remains same. The series resonance circuit of is as shown in

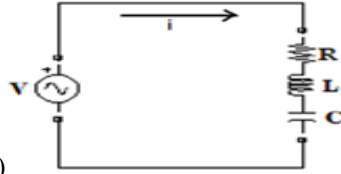

figure(i)

Fig.(i)Series resonance circuit

So Energy stored in inductor = $\frac{1}{2} LI^2$

Energy stored in capacitor = $\frac{1}{2} CV^2$

At condition of resonance in RLC circuit the resonance frequency is

$$f_o = \frac{1}{2 * \pi * \sqrt{LC}}$$

A. Design of resonance circuit parameter

The secondary inductance of transformer is

$$L_{sec} = 20\mu H$$

The inductance of heating coil by measuring on LCR meter are ;

$$\text{At } 100\text{Hz the } L_{coil} = 2.86\text{mH}$$

$$\text{At } 1\text{KHz the } L_{coil} = 52.1 \mu H$$

Then from the analysis of frequency with inductance graph [11]

$$\text{At } 50 \text{ KHz the } L_{coil} = 46 \mu H$$

$$\text{Total inductance } L = 66 \mu H$$

At resonance condition in series RLC circuit

Inductive reactance = Capacitive reactance

$$X_L = X_C$$

$$2\pi fL = \frac{1}{2\pi fC}$$

Put $f = 50 \text{ KHz}$ $L = 66 \mu H$ in above equation then

$$2\pi fL - \frac{1}{2\pi fC} = \frac{2}{100} = 0.02$$

$$2 * \pi * 50 * 10^3 * 66 * 10^{-6} - \frac{1}{2 * \pi * 50 * 10^3 * C} = 0.02$$

$$20.7345 - \frac{1}{2 * \pi * 50 * 10^3 * C} = 0.02$$

$$\frac{1}{2 * \pi * 50 * 10^3 * C} = 20.7145$$

$$C = 0.154 \mu F$$

VII. SIMULATION OF HIGH FREQUENCY FULL BRIDGE INVERTER FOR INDUCTION HEATING

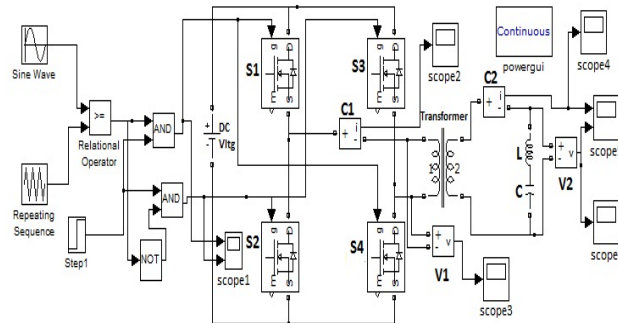

Fig.(j) Simulation of high frequency full bridge inverter for induction heating.

When 250v dc supply is given to the inverter, it is converted into the high frequency ac supply i.e. 50 kHz. MOSFET is used as a switching device and the Bipolar PWM method is used to control the inverter. The output of inverter is applied to step down transformer this results in low output voltage of transformer due to which the current flowing in the heating coil increases i.e. required for induction heating. The work piece to be heated is placed in heating coil. The simulation of high frequency full bridge inverter for induction heating is done in MATLAB/SIMULINK is as shown in figure.

SIMULATION RESULTS:

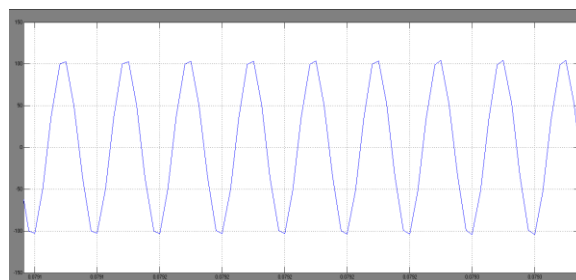

Fig.(k) Waveform of output current flowing in resonance circuit.

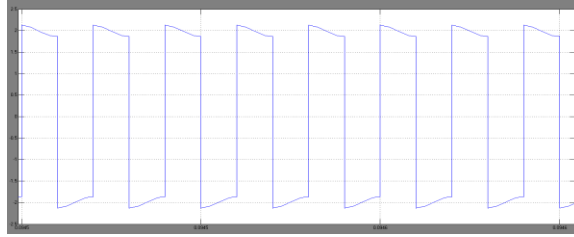

Fig.(l) Waveform of output voltage across the resonance circuit.

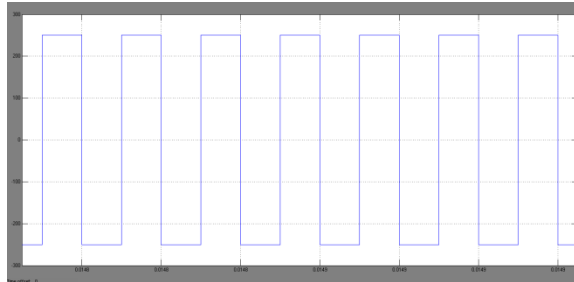

Fig.(m) Waveform of output voltage of an inverter.

VIII. CONCLUSION

In this paper a high frequency full bridge induction heating has been proposed. MOSFET is used as a switching device for full bridge inverter which has higher power handling capacity and PWM switching technique is used to control the inverter frequency. The main advantage of full bridge inverter is that it supplies more power than half bridge inverter and reduces noise. The simulation is done in MATLAB/SIMULINK. The high frequency resonant inverter based induction heating system is used for industrial applications and it can be developed and improved to meet the requirements in different area such as in medicinal application, sterilization plants, heat treatment plants and auto mobile manufacturing plants. It can also be used in platinum, gold jewelry and manufacturing industry. Microwave oven cooking is replaced by induction cooking because induction heating has quick start up and easy temperature control.

REFERENCES

- [1]D.VijayaBhaskar and N.Vishwanathan, "Full Bridge Series Resonant Inverter for Induction Cooking Application," *IEEE 5th India International conference on Power Electronics (IICPE)*.pp 1-5, Dec 2012.
- [2]MokhtarKamli and Minoru Abe, "A 50-150 kHz Half-Bridge Inverter for Induction Heating Applications," *IEEE Transaction on Industrial Electronics*, Vol.43, No.1, February 1996.
- [3]SaicholChudjuarjeen and AnawchSangswang, "An Improved LLC Resonant Inverter for Induction Heating Applications with Asymmetrical Control," *IEEE Transaction on Industrial Electronics*, Vol.58, No.7, July 2011.
- [4]N.Sanajit and A.Jangwanitlert "A Series-Resonant Half-Bridge Inverter for Induction Iron Applications," *IEEE Ninth International Conference on Power Electronics and Drive Systems (PEDS)*, pp 46-50, Dec 2011.
- [5]O.Lucia and J.M.Burdio, "Induction Heating Technology and its Applications: Past Developments, Current Technology, and Future Challenges," *IEEE Transaction on Industrial Electronics* Vol.61 pp 2509-2520, May 2014.
- [6]AmiraZouaouiKhemakhem, "An Improved LLC Resonant Inverter For Induction Heating Applications," *International Conference on Electrical Science and Technologies in Mughreb (CISTEM)*, pp 1-7, Nov 2014.
- [7]Jose M. Burdio and Luis A. Barragan, "Asymmetrical Voltage-Cancellation Control for Full-Bridge Series Resonant Inverters," *IEEE Transaction on Power Electronics*.Vol.19, No.2.March 2004.

[8]S.Arumugam and S. Ramareddy, "Exprimental Studies on Full Bridge Resonant Inverter Fed Induction Heating Sytem," *IEEE-International Conference On Advances In Engineering, Science And Management (ICAESM-2012)*, pp 32-38 March 2012.

[9]YonglongPeng, Jun Xu and Yabin Li, "Modeling and Simulation of an Improved PLL-Controlled Circuit for Series Resonant Inverter," *International Conference on Electrical Machines and Systems (ICEMS)*, Oct.2008.

[10]SaicholChudjuarjeen and ChayantKoompai "Asymmetrical control with Phase Lock Loop for Induction Cooking Appliances," *5th International Conference on Electrical Engineering/Electronics, Computer, Telecommunications and information Technology, Vol.2*, pp 1013-1016, May 2008.

[11]Gabrielegrandi,Marin K. Kazimierczuk "Model of Laminated Iron-Core Inductors for High frequencies." *IEEE Transaction on magnetic* ,Vol.40, No.4, July 2004.